

Tension brake sizing

Two important parameters are used in brake selecting:

- Max. torque requirement
- Max. thermal power to be dissipated

These two values are determined by the application (see calculation example on pages 52-53).

ELECTROMAGNETIC BRAKE TYPE TB – SELECTION

TB brake selection is based on two values :

Max torque need (Nm) on the brake

*Max brake rotation speed for the max torque (rpm)

* As the curve given for TB selection takes the power dissipation into account, this value is used.

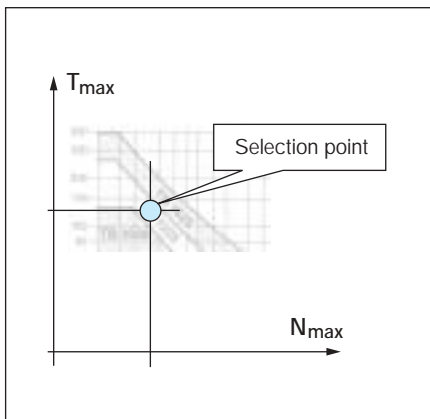

T_{max} = **torque** needed at the brake for the max tension in material and the max roll diameter - taking any gear ratios into account.

N_{max} = brake rotation **speed** for the max linear speed and the max roll diameter – taking any gear ratios into account.

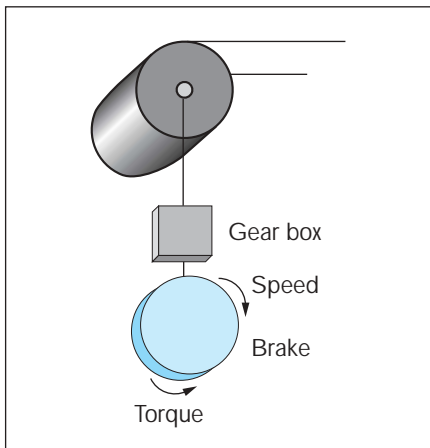

Note : the constant tension in the web gives a constant power on the brake. However, we make the selection for the max torque (then at full roll diameter) because it's the moment where the brake has the least natural cooling.

TB brake selection

The table (pictured below left) illustrates the selection of the correct **TB brake**. The table on the right determines the maximum torque provided by the brake when nominal voltage is applied. After selection you can consult the complete brake characteristics and dimensions on pages 30 to 31.

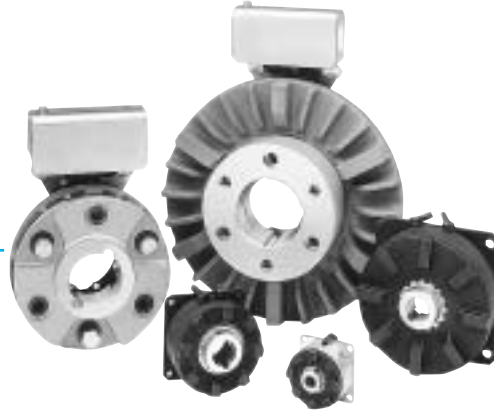

**Dynamic braking torque
TB170 - TB1525**

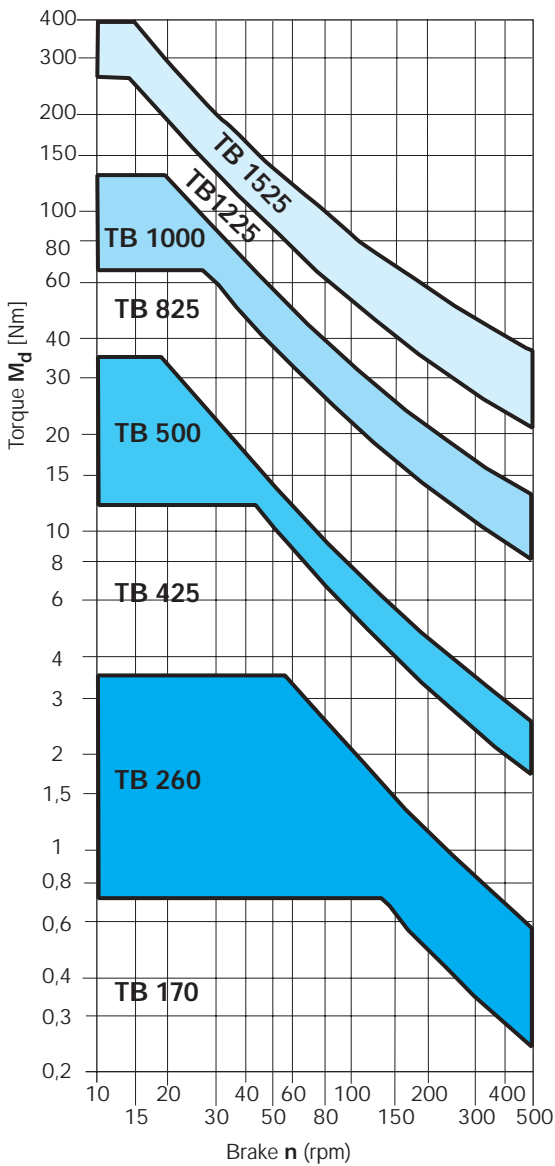

**Maximum braking torque (emergency stop)
TB170 - TB1525**

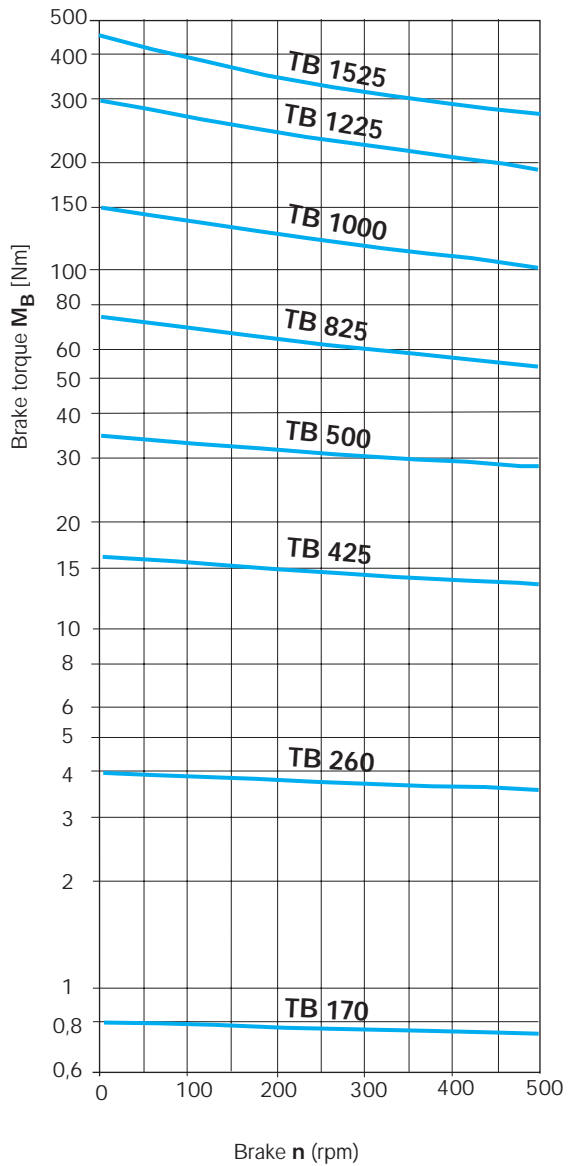

TB brake characteristics

TB units are assembled using various parts described below. Main components of the brake are armature and magnet. Additional parts are offered to provide for ease of mounting.

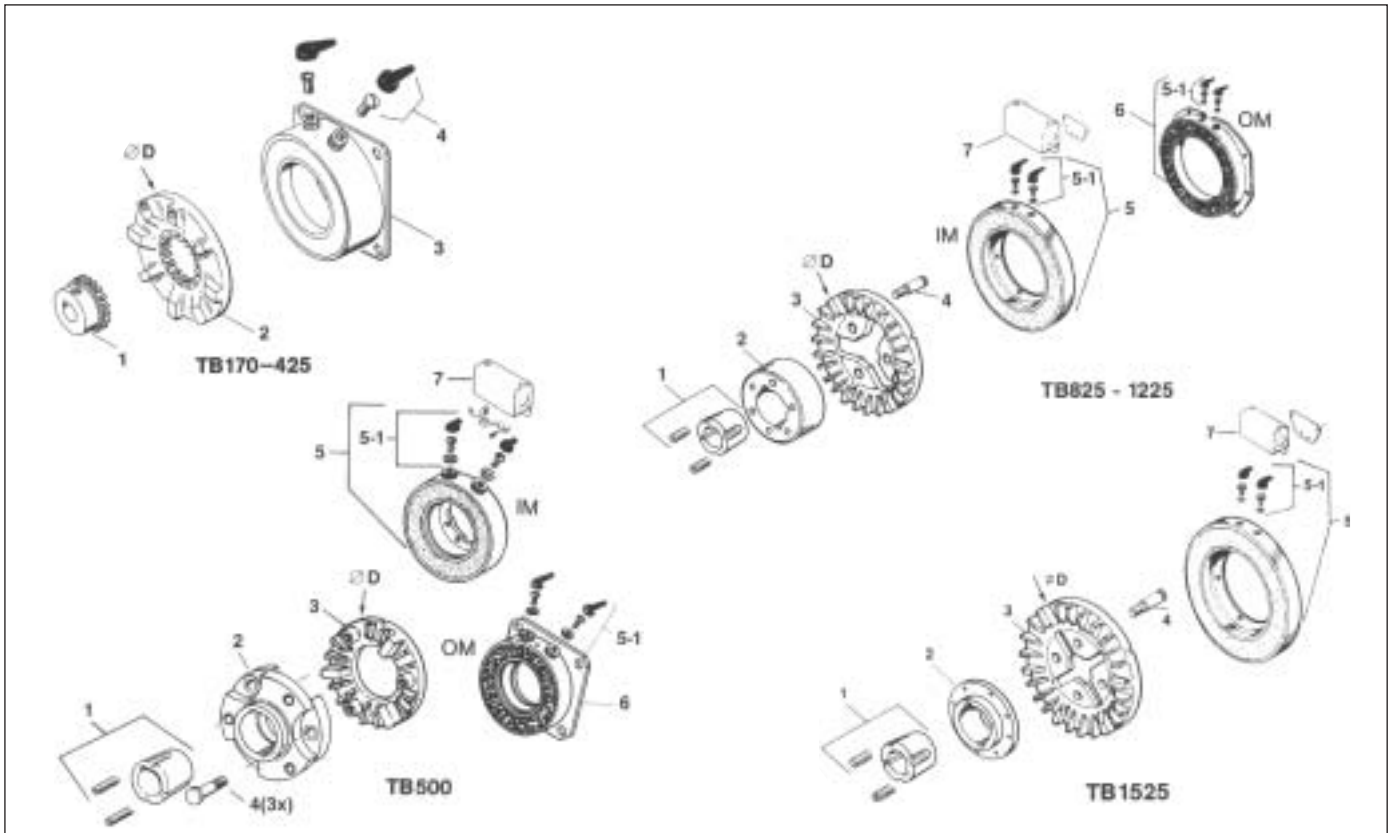

Part	TB170	TB260	TB425
	D = 46 mm	D = 69 mm	D = 111 mm
1 Armature hub*	B5102-541-001-38	B5103-541-001-47	B5104-541-001-31
2 Armature	K110-0096	K110-0097	K110-0098
3 Magnet 24V	K375-631-012 R = 110 Ω, 20°C	K5365-631-016 R = 60 Ω, 20°C	K5367-631-008 R = 76 Ω, 20°C
4 Terminals	Wires	B5103-101-002	B5103-101-002

* Prebored

** Indicate bore and keyway

Part	TB500
	D = 130 mm
1 Taperlock bushing**	B180-xxxx-xxxx
2 Armature hub	K5300-541-004
3 Armature	B110-0047
4 Drive pins	K5300-101-003 3 x
5 Magnet IM 24V	B5300-631-040
5-1 Terminals	B5311-101-001
6 Magnet OM 24V	B5300-631-000-46
7 Conduit box	K5200-101-010

Part	TB825	TB1000	TB1225	TB1525
	D = 215 mm	D = 259 mm	D = 316 mm	D = 395 mm
1 Taperlock bushing**	B180-xxxx-xxxx	B180-xxxx-xxxx	B180-xxxx-xxxx	B180-xxxx-xxxx
2 Armature hub	B540-0394	B540-0313	B540-0015	B540-0314
3 Armature	B5301-111-019	B5302-111-021	B5303-111-011	B5304-111-005-04
4 Drive pins	B5301-101-001 3 x	B5301-101-001 3 x	B5301-101-001 4 x	B5301-101-001 4 x
4 Magnet IM 24V	B5311-631-000-30 R = 20 Ω, 20°C	B5312-631-000-36 R = 20 Ω, 20°C	B5313-631-000-11 R = 22 Ω, 20°C	B5314-631-000-08 R = 20 Ω, 20°C
5-1 Terminals	B5311-101-001	B5311-101-001	B5311-101-001	B5311-101-001
6 Magnet OM 24V	B5311-631-000-16	-	-	-
7 Conduit box	K5200-101-011	K5200-101-011	K5200-101-011	K5200-101-011

TB brake characteristics

All **TB brakes** are rated at 24 VDC nominal. When selection is correct the voltage on the brake should be approximately 12 VDC for your maximum parameters used in calculation. All **TB brakes** are able to work for short periods of time (less than 10 seconds) in the 12-24 VDC range, for example in machine deceleration or in emergency stop.

Technical data and dimensions

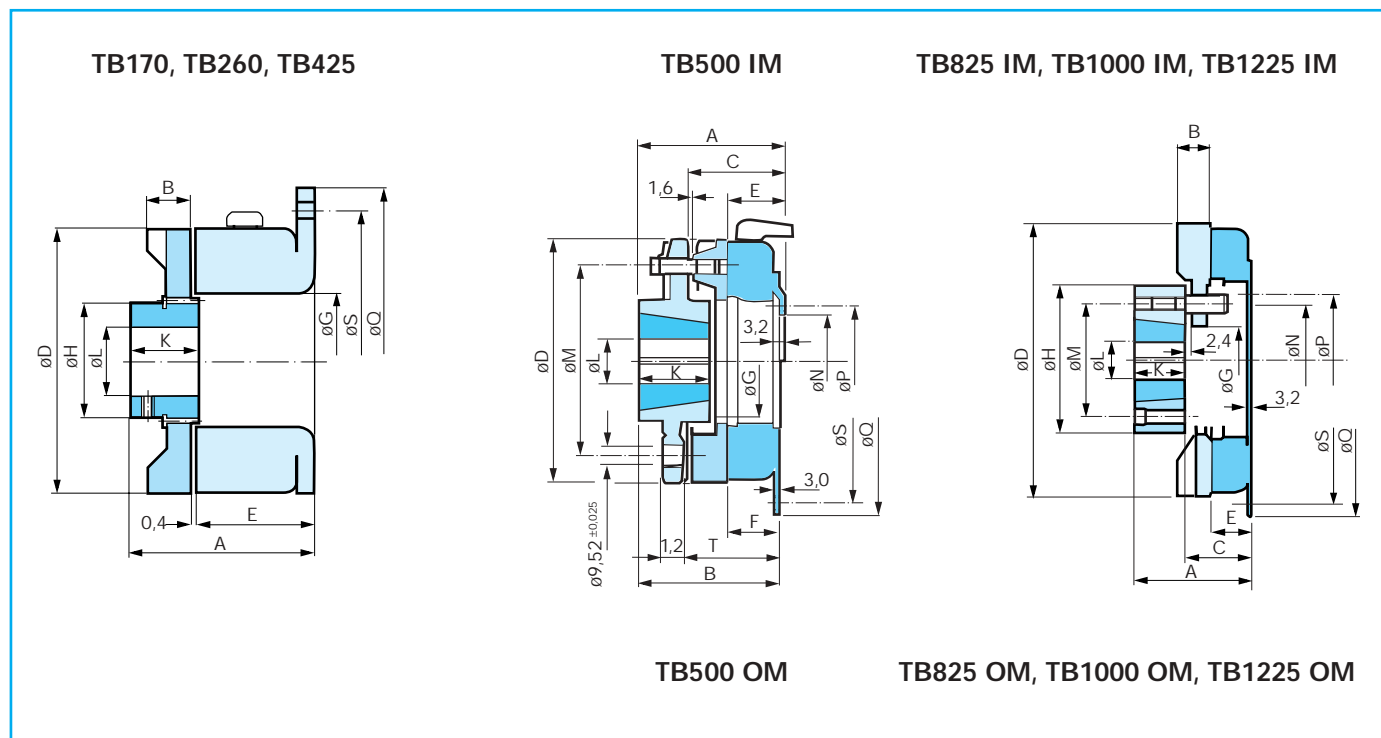

Size		TB170	TB260	TB425	TB500	TB825	TB1000	TB1225	TB1525
M_d	[Nm]	0,8	4	16,5	35	75	150	300	450
M_d min	[Nm]	0	0,08	0,16	0,2	0,5	1,1	2	3
n max	[rpm]	5000	5000	5000	5000	3000	2400	2000	1600
I 24V =	[A]	0,22	0,40	0,32	1,010	1,177	1,224	1,076	1,212
P* Continu	[kW]	0,015	0,030	0,060	0,100	0,200	0,360	0,520	0,810
P* Alternativ	[kW]	0,022	0,045	0,100	0,180	0,360	0,650	0,950	1,580
R 20° C	[Ω]	110	60	76	23,8	20,4	19,6	22,3	19,8
t_b	[s]	0,020	0,040	0,080	0,052	0,112	0,152	0,290	0,310
Inertia	[kgm ²]	$12 \cdot 10^{-6}$	$116 \cdot 10^{-6}$	$1,4 \cdot 10^{-3}$	$1,9 \cdot 10^{-3}$	0,022	0,041	0,095	0,213
Mass	[kg]	0,180	0,650	1,800	2,3	8,2	12	21	27,5
A	[mm]	30,5	48,5	52	79	94	105	138	116
B	[mm]	7	12	14	77	30,5	30,5	30,5	30,5
C	[mm]	-	-	-	51	54	56,5	62	65
øD	[mm]	46	69	111	130	215	259	316	395
E	[mm]	20,6	32	30,5	30,5	33,5	36,5	41,5	44,5

* Alternativ duty based on 30 minutes ON and 30 minutes OFF.

TB brake characteristics

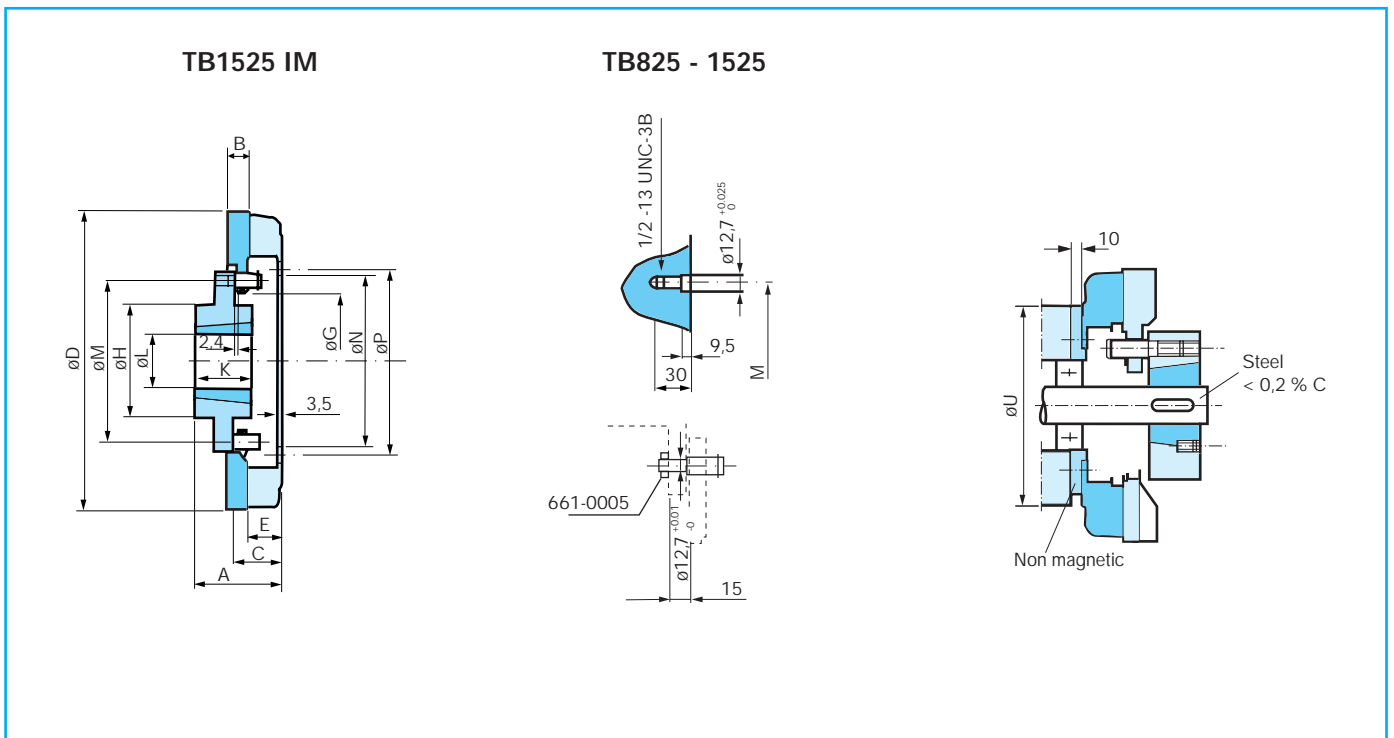

Size		TB170	TB260	TB425	TB500	TB825	TB1000	TB1225	TB1525
F	[mm]	-	-	-	28,5	-	-	-	-
øG	[mm]	19,5 ^{+0,05}	35	62	49	55	98	114	180
øH	[mm]	15,9	30,1	31,8	-	118	159	175	152,5
K*	[mm]	10,3	17,5	22,2	38	38	44,5	76	76
øL max	[mm]	10	20	22	32	42	60	75	75
øM ^{±0,025}	[mm]	-	-	-	98,42	90,49	133,4	149,3	215,9
					3 × 120°	3 × 120°	3 × 120°	4 × 90°	4 × 90°
øN ^{±0,05}	[mm]	-	-	-	52,40	88,93	136,55	161,95	228,60
øP (for screw)	[mm]	-	-	-	60,3	108	155,6	184,1	247,60
					8 × M4	6 × M8	6 × M8	6 × M8	12 × M8
øQ _{-0,05}	[mm]	61,9	88,9	142,47	165,10	247,62	-	-	-
øS (for screw)	[mm]	54	79,4	127	149,2	255,5	-	-	-
		4 × M4	4 × M4	4 × M6	4 × M10	4 × M8	-	-	-
T	[mm]	-	-	-	49	-	-	-	-
øU	[mm]	-	-	-	110	170	220	260	340

* Reverse mounting of taperlock bushing is possible

Tension brake for strapping machine

Specially designed for strapping machine, the **electromagnetic brake TBM10** is adjustable for the different kind of plastic film. Mounted on the intermediate roller, it will tighten the plastic film and will permit a perfect strapping.

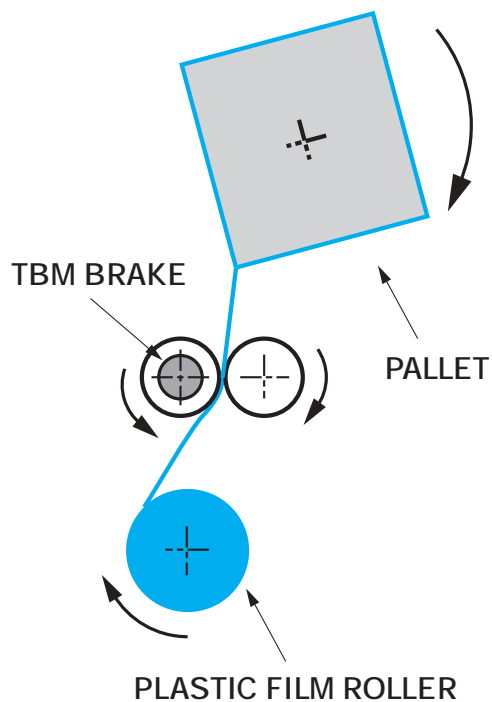

TBM SIZE 10

Heat dissipation torque

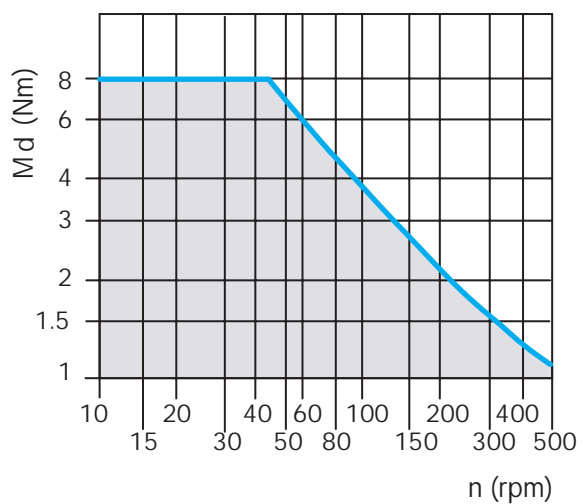

Brake torque

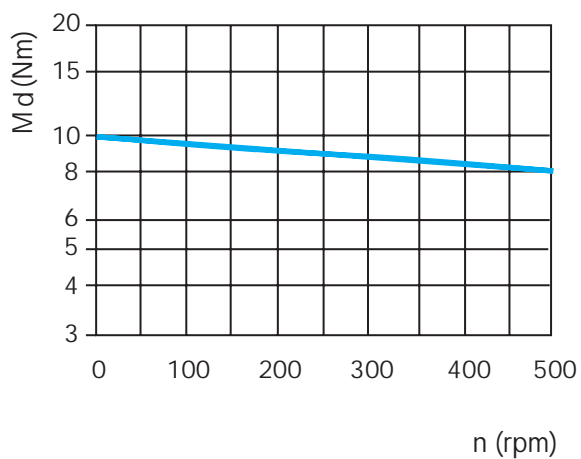

Tension brake for strapping machine

TBM SIZE 10

VAR 03

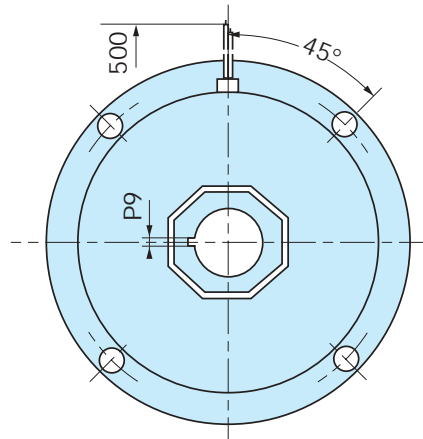
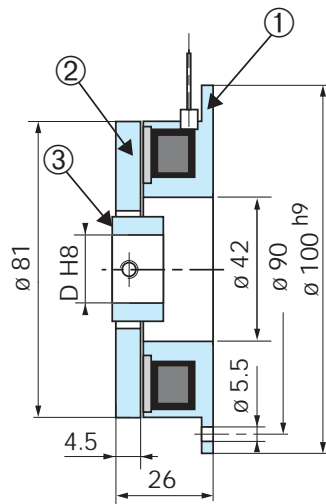

D min = 8 mm with standard keyway
D min = 13 mm with standard keyway

VAR 04

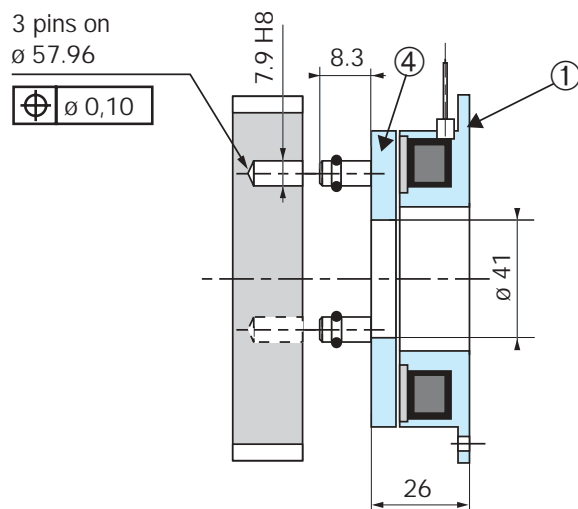

U max : 24 VDC - P 20°C = 10,8 Watts

Keyway according to : ISO R773 / BS 4235 /
NFE 22175 / tolerance P9

	Part	TBM TAILLE 10
1	Inductor 24VDC	B6650-631-000-39
2	Armature VAR03	B110-0000-1358
3	Hub prebored $\varnothing 7,5$	B540-0000-2519
	Hub $\varnothing 12$ H8 + Keyway 4 P9	B540-0000-2517
4	Armature VAR04	B6650-111-000-08