

Description

The **E8P** optical incremental kit encoder is designed for high volume, low cost, mid-resolution OEM motion control applications. The **E8P** is small enough for a NEMA Size 11 stepper motor. The **E8P** uses a single 5V supply and offers two TTL quadrature outputs. Single-ended or differential output options are available. A single chip reflective encoder module incorporates an LED, monolithic detector and molded lenses. The phased array technology accepts far wider mechanical tolerance and misalignment than traditional aperture type encoders. The **E8P** uses an innovative, patent pending, push-on encoder disk that provides extremely secure and accurate, yet easy installation without setscrews.

The **E8P** provides mounting holes for two #4-40, length .250" screws or two M2.5x.45mm, length 6mm screws on a 0.75" diameter bolt circle. When mounting holes are not available, an option with a transfer adhesive pre-applied to the base is available. A centering tool is provided to center the base to the motor shaft during installation. The encoder disk pushes on by hand using a spacer tool to set the gap in one step. The cover snaps on to complete the assembly in seconds.

The single-ended output version has a 4-pin high retention polarized connector and is designed to drive cables up to six feet long. For longer cable lengths, the differential output version (6-pin connector) is recommended to maximize noise immunity. The internal 26C31 differential line driver can source and sink 20 mA at TTL levels. The recommended receiver is industry standard 26C32. Maximum noise immunity is achieved when the differential receiver is terminated with a 150 Ω resistor in series with a .0047 μ F capacitor placed across each differential pair. The capacitor simply conserves power. Otherwise power consumption would increase by approximately 20 mA per pair, or 40 mA for 2 pairs.

Mechanical Drawing



Features

- ▶ Subminiature size, easy installation
- ▶ Single-ended or differential output option
- ▶ A and B quadrature TTL outputs
- ▶ Fits shaft diameters from 0.118" (3mm) to 0.276" (7mm)
- ▶ Accepts +/- 0.020" axial shaft play
- ▶ Off-axis mounting tolerance of 0.010"
- ▶ Count frequency from DC to 30 kHz
- ▶ 180 to 512 cycles per rev (CPR)
- ▶ 720 to 2048 quadrature states per rev.
- ▶ Single +5V supply

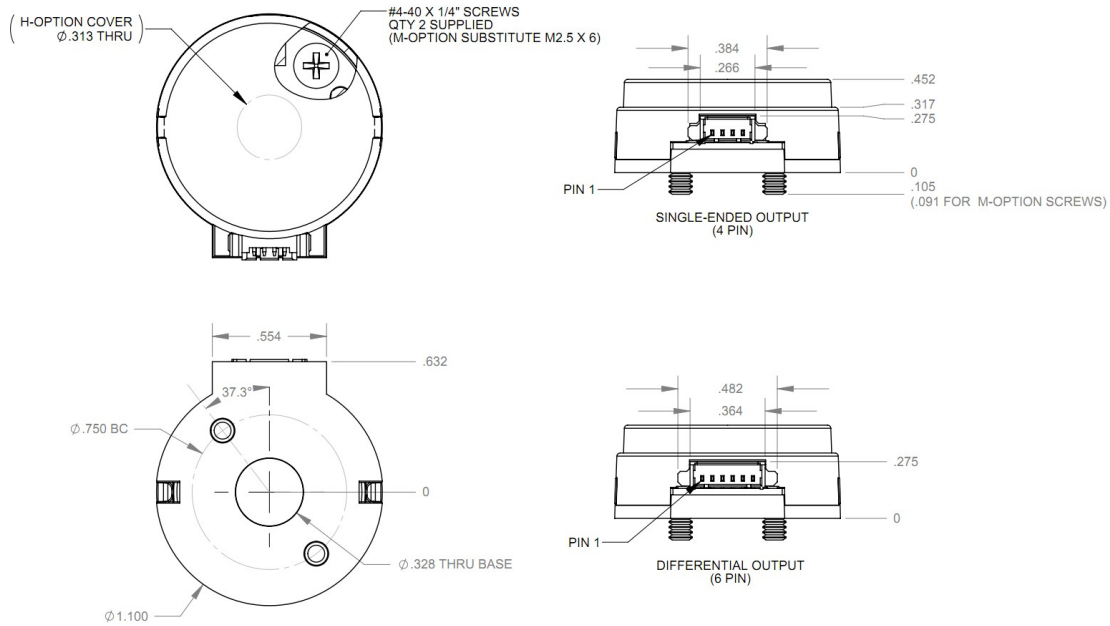

Environmental

Parameter	Value	Units
Vibration (5Hz to 2kHz)	20	G
Max. Relative Humidity	90	%
Storage Temperature	-40 to 100	C
Operating Temperature	-20 to 100	C
Electrostatic Discharge, IEC 61000-4-2		
Single-ended (S-option)	± 8	kV
Differential (D-option)	± 2	

Mechanical

Parameter	Value	Units
Moment of Inertia	1.81×10^{-5}	oz-in-s ²
Required Shaft Length		
With D-Cover option	0.385" to 0.400"	in.
With H-Cover option	≥ 0.385 "	in.
Mounting Screw Torque (-D, -M option)	2-3	in.-lbs
Shaft Axial Play	$\pm .020$	in.
Off-axis Mounting Tolerance	$\pm .010$	in.

Parameter	Value	Units
Acceleration	250000 max.	rad/sec ²
Maximum RPM (1) e.x. CPR = 720, max. rpm = 5000 e.x. CPR = 180, max. rpm = 20000	minimum value of (3600000/CPR) and (60000)	rpm
Technical Bulletin TB1001 - Shaft and Bore Tolerances		Download

(1) 60000 rpm is the maximum rpm due to mechanical considerations. The maximum rpm due to the module's 30kHz maximum count frequency is (3600000/CPR).

Base Options

Base Option	Bolt Circle	Screws Included
D	0.75"	#4-40, length .250" pan head phillips (qty: 2)
M	0.75"	M2.5x.45mm, length 6mm pan head phillips (qty: 2)
T	n/a	none - .005" thick transfer adhesive with peel away backing mount.

The included centering tool and spacer tool are used to center the base to the motor shaft and to set the codewheel gap.

Single-ended Electrical

Specifications	Min.	Typ.	Max.	Units	Notes
Supply Voltage	4.5	5.0	5.5	V	
Supply Current		21	27	mA	no load
Low-level Output			0.4	V	IOL = 6 mA
High-level Output	2.4			V	IOH = -1 mA
Rise Time		500		ns	CL = 25 pF, RL = 2.7 kΩ
Fall Time		100		ns	

Differential Electrical

Specifications	Min.	Typ.	Max.	Units	Notes
Supply Voltage	4.5	5.0	5.5	V	
Supply Current		23	30	mA	
Low-level Output		0.2	0.4	V	IOL = 20mA max.
High-level Output	2.4	3.4		V	IOH = -20mA max.
Differential Output Rise/Fall Time			15	ns	

Phase Relationship

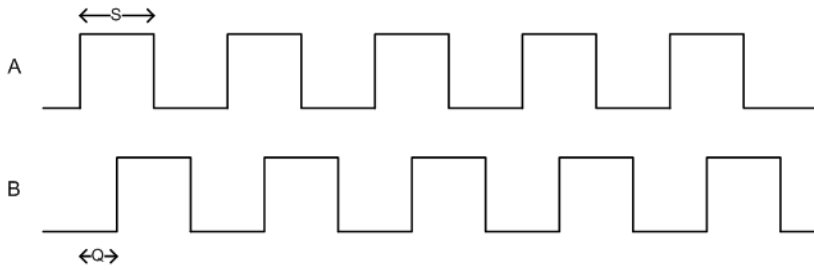

Parameter	Typ.	Max.	Units
Symmetry, S	180 ± 16	180 ± 75	electrical degrees
Quadrature Delay, Q	90 ± 10	90 ± 60	electrical degrees

(1) A leads B for clockwise shaft rotation, and B leads A for counterclockwise rotation viewed from the cover/label side of the encoder.

(2) Typical values represent the encoder performance at typical mounting alignment, whereas the maximum values represent the encoder performance across the range of recommended mounting tolerance.

Pin-outs

4-pin Single-ended (1)		6-pin Differential (2)	
Pin	Description	Pin	Description
1	+5VDC power	1	Ground
2	A channel	2	A channel
3	Ground	3	A- channel
4	B channel	4	+5VDC power
		5	B channel
		6	B- channel

(1) 4-pin single-ended mating connector isCON-MIC4

(2) 6-pin differential mating connector isCON-MIC6

Assembly Instructions

1. PCB Installation

Position the PCB so that connector lines up with flat side of base. Push PCB onto base by hand so that the two guide posts fit into associated PCB holes.

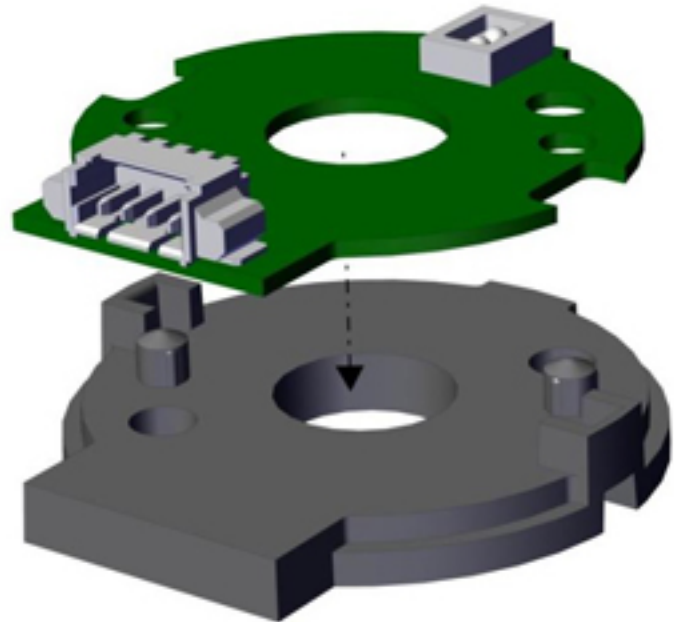

2. Base Installation

2a. **Standard:** Secure base to mounting surface with provided mounting screws.

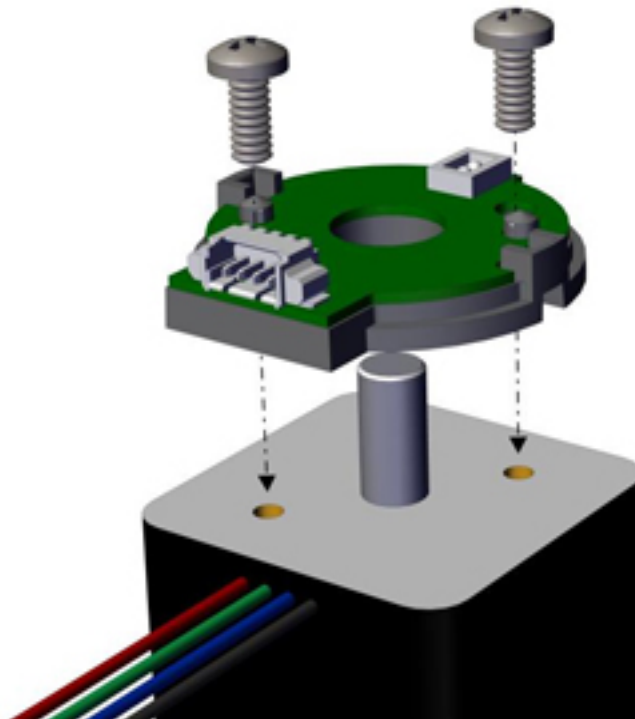

2b. **Transfer Adhesive:** Slip centering tool over shaft and into center hole of base. Slide both parts down shaft until they contact mounting surface. Press base firmly to assure good adhesion. Remove centering tool.

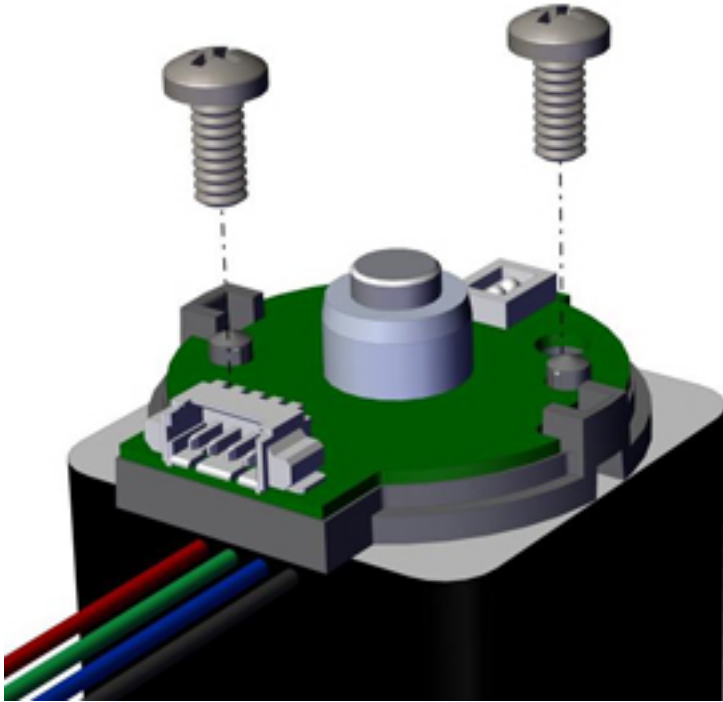

3. Codewheel Installation

Set codewheel on shaft with disk facing base. Place spacer tool over codewheel with recess areas over connector and base tabs. Push tool down by hand until it bottoms out against base. Remove reusable spacer tool. In order to prevent permanent damage to motor bearings (especially on small diameter shaft motors), it is recommended that the far end (drive end) of the motor shaft be supported while installing the push on hub.

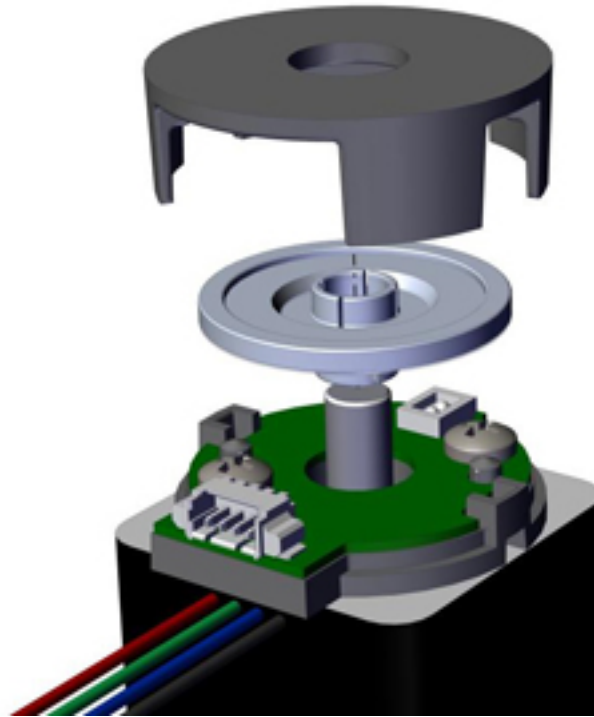

4. Cover Installation

Snap cover onto base.

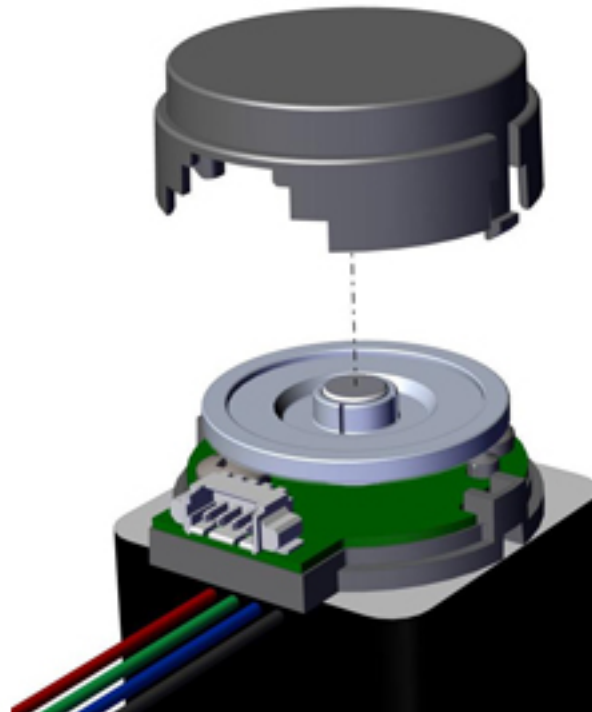

 **Accessories****1. Centering Tool**

The centering tool is only included with the **-3** packaging option. It has to be ordered separately for other packaging options.

Part #: CTOOL - (Shaft Diameter)

Description: This reusable tool provides a simple method for accurately centering the **E7P** base to the shaft. A centering tool is highly recommended when using the **T**-option transfer adhesive.

2. Spacer Tool

A spacer tool is included for all packaging options.

Part #: SPACER-E8P

Description: This reusable tool is used to properly space the codewheel from the encoder.

Ordering Information

E8P	-	<input type="text"/>	-	<input type="text"/>	-	<input type="text"/>	-	<input type="text"/>	-	<input type="text"/>	-	<input type="text"/>
CPR		Bore		Output		Cover		Base		Packaging		
180 =		118 =		S =Single-ended		D =Default		D =Default (Two #4-40, length .250" mounting screws)		B =Encoder components packaged in bulk. One spacer and one centering tool per 100 encoders.		
200		3mm		D =Differential		H =Hole in Cover		M =Two M2.5x.45mm, length 6mm mounting screws		1 =Each encoder packaged individually. One spacer tool and one centering tool per 100 encoders.		
360 =		157 =						T =Adds transfer adhesive to base		2 =Each encoder packaged individually. One spacer and one centering tool per encoder.		
400 =		4mm										
500 =		197 =										
512 =		5mm										
		236 =										
		6mm										
		250 =										
		1/4"										
		276 =										
		7mm										

Notes

- Cables and connectors are not included and must be ordered separately.
- US Digital warrants its products against defects in materials and workmanship for two years. See complete warranty for details.

Base Pricing

Quantity	Price
1	\$35.99

For volume discounts, please contact us at sales@usdigital.com or 800.736.0194.

- Add 25% per unit for **Output** of Differential
- Add 15% per unit for **Base** of Adds transfer adhesive to base
- Add \$4.00 per unit for **Packaging** of Each encoder packaged individually. One spacer tool and one centering tool per 100 encoders.
- Add \$7.00 per unit for **Packaging** of Each encoder packaged individually. One spacer and one centering tool per encoder.